

Interactor Training

**Module 11
INDIRECT FIRE
vA13.000**

INDIRECT FIRE

Select IFIR.



DEPLOY	START	ADMIN				
GROUP	1	2	3	4	5	
	6	7	8	9	10	
RE-ORG	001	FORCE	001			
COUNTER	00000					
TIMER	00:00:00:00					
GR99A	PP	02000	87001			
RTE	ALT	DEL	CAN	COPY		
ISTOP/GD	HALT		GO			
MOVE	SHOW	SPEED	MAXIMUM			
MOUNT	TRANSFER	ASSIGN				
DISMNT	LINE-F	DEFL	PIT			
VIEW	FORWARD	LOS	FACE			
IC	GP	FM	FC	SD		
ROE	HOLD	SMOKE	GRENADE			
LOGS	TRACKER	OPFOR				
INFO	DATA		DETECT			
	MISC	ISR				
DFIR	FORM	SOP	URBAN			
IFIR	AYN	ENG	LOG			
PLN	ALT	EOM	C/F			
ADJ	TIME	PRI				
	HE	CONV				
	000RFFE,	FB	Rate			
	000For	000Mins				
	LRP	DF				
ICRPT	IFRPT	INFO				
Zm	DF	1	2	3	4	5
PREV	NEXT	PAN	GRID			
CLDS	FRDS	ENMY	HULK	DBS		
CLEAR	UP	DN	PRINT			

IFIR INFO

Activate IFIR Sub-menu

Select **IFIR**



Select **INFO**



Select **ICON:**

Planning Data Display



Ammunition Status Display

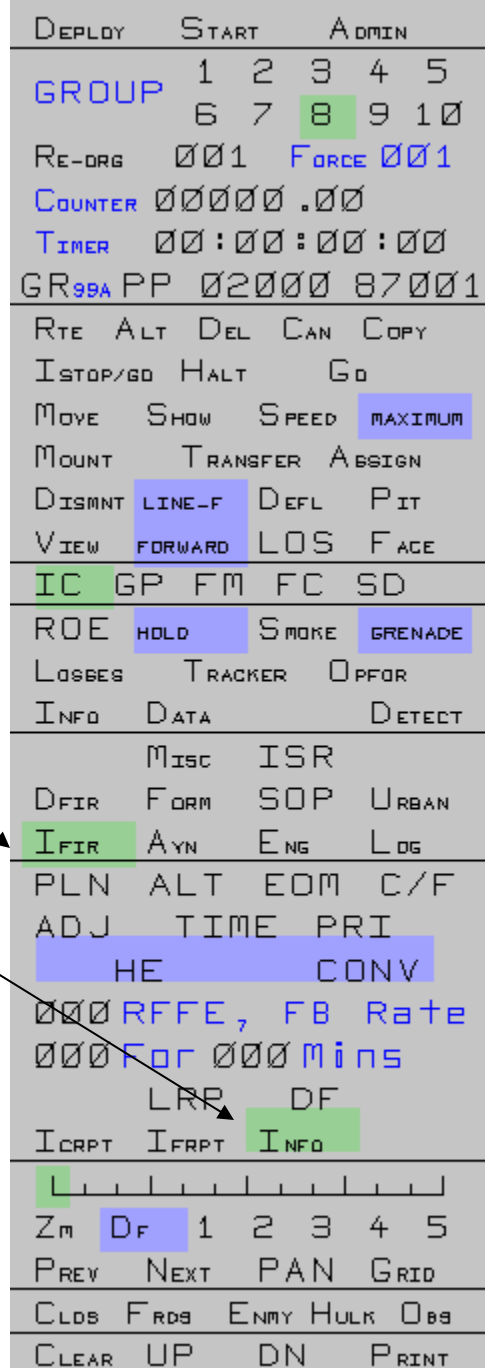
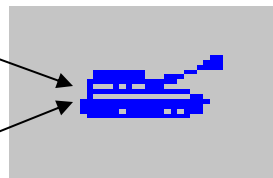

IFIR INFO

```

M109AG          1 Bty   ( 22:1)

  Plan  Reload  Max Rng
HE   50    20    24000m
HC   50    20    22000m
IC   50    20    24000m

Setup time    90.0 secs
Packup time   30.0 secs
    
```

```

M109AG          1 Bty   ( 22:1)

  Wpn Initial  Current  L Range
                    Ready Store
HE:  540:  540:  0: :24.00
HC:  396:  396:  0: :22.00
IC:   60:   60:  0: :24.00
50 Pintl: 3600: 3600: 0: : 2.00
    
```

```

DEPLOY  START  ADMIN
GROUP   1  2  3  4  5
        6  7  8  9 10
RE-ORG  001  FORCE 001
COUNTER 00000.00
TIMER   00:00:00:00
GR99A PP 02000 87001

RTE ALT DEL CAN COPY
ISTOP/GD HALT  GD
MOVE  SHOW  SPEED  MAXIMUM
MOUNT TRANSFER ASSIGN
DISMNT LINE-F DEFL PIT
VIEW  FORWARD LOS FACE
IC GP FM FC SD
ROE  HOLD  SMOKE  GRENADE
LOGSBS TRACKER OFFOR
INFO  DATA  DETECT

      MISC  ISR
DFIR  FORM  SOP  URBAN
IFIR  AYN  ENG  LOG
PLN  ALT  EOM  C/F
ADJ  TIME  PRI
      HE  CONV
000RFFE, FB Rate
000For 000Mins
      LRP  DF
ICRPT IFRPT INFO
L | | | | | | | | | | | | | | | |
Zm DF 1 2 3 4 5
PREV NEXT PAN GRID
CLDS FRDS ENMY HULK OBS
CLEAR UP DN PRINT
    
```

Planning Data Display

Ammunition Status Display

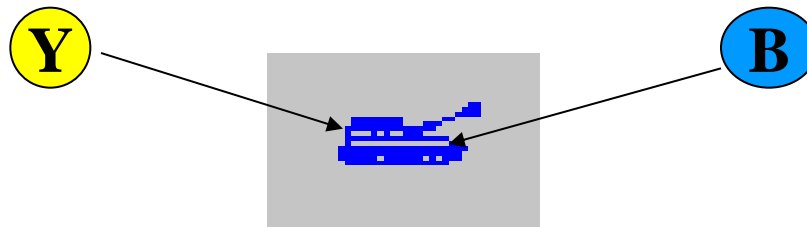

Select **ICON**:

INDIRECT FIRE

Create a Mission



To create an Indirect Fire mission, follow the **sequence**:

- Set Mission Details [on counters].
- Set Impact point [using PLAN options].
- Select Fire Unit (s).

SET
MISSION DETAILS

IFIR

AMMUNITION TYPES

Click on HE with / and toggle through the options.  Defaults to HE.

HE	=	High Explosive
SMOKE HC	=	Smoke Hexachlorethane
CHEMICAL	=	Chemical (semi -persistent Nerve agent)
ICM	=	Improved Conventional Munitions
PG1	=	Precision Guided Munitions Type 1 (like Copperhead)
PG2	=	Precision Guided Munitions Type 2 (like Hellfire)
FASCAM	=	FASCAM (Anti -armour mines delivered by artillery)
SMOK E WP	=	Smoke White Phosphorous
SMOKE BS	=	Smoke Bi-Spectral
FLECHET	=	Flechette (A large quantity of tiny projectiles)
ROCKET	=	Rocket Propelled Projectile
TERMINAL	=	Terminally guided Munitions

Current Representations:

TERMINAL. Represents SMArt 155 mm Munition:

- Terminal Guided Sub-Munition
- 2 x sub-munitions.
- Each sub-munition searches a 100 m radius.
- Target – Armoured vehicles.
- Fires an explosively formed 'slug' from above.

ROCKET. Represents Excalibur Munition:

- GPS/INS guidance.
- HE round with reduced Net Explosive Content.
- Very accurate against stationary targets.
- Not intended for moving targets.

IFIR

IMPACT PATTERNS

- a. Converge
- b. Linear [Interactor defines]
- c. Sheath [pre-set 200x200, 400x400, 600x600]
- d. Area [Interactor defines]
- e. Fascam [Panels Type 1 -10]

IFIR

Impact Patterns

Y Toggle **Impact Pattern** options.

```

ALERT CBR
DFIR FORM SOP URBAN
IFIR AYN ENG LOG
PLN LRP DF ALT
ADJ TIME PRI
HE CONV
006RFFE, FB Rate
000For 000 Mins
C/F
ICRPT IFRPT INFO EOM
  
```

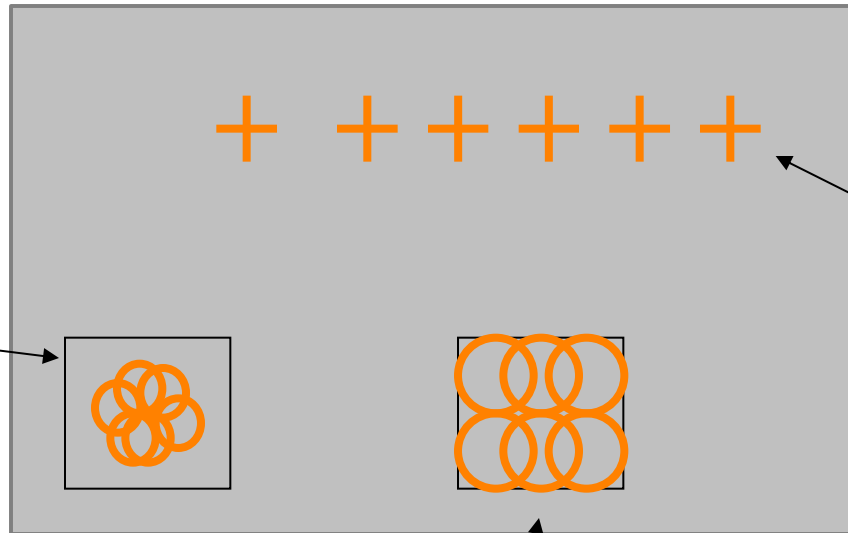

```

ALERT CBR
DFIR FORM SOP URBAN
IFIR AYN ENG LOG
PLN LRP DF ALT
ADJ TIME PRI
HE LINEAR
006RFFE, FB Rate
002For 010 Mins
C/F
ICRPT IFRPT INFO EOM
  
```

```

ALERT CBR
DFIR FORM SOP URBAN
IFIR AYN ENG LOG
PLN LRP DF ALT
ADJ TIME PRI
HE SH 200
006RFFE, FB Rate
002For 010 Mins
C/F
ICRPT IFRPT INFO EOM
  
```

IFIR

Rates of Fire

- a. RFFE = Rounds fire for effect
- b. FB Rate = Follow By (Rounds/Time)

IFIR

Set Mission Details

Toggle ammunition type and impact pattern



Toggle Rounds Fire For Effect



Toggle Followed by Rate

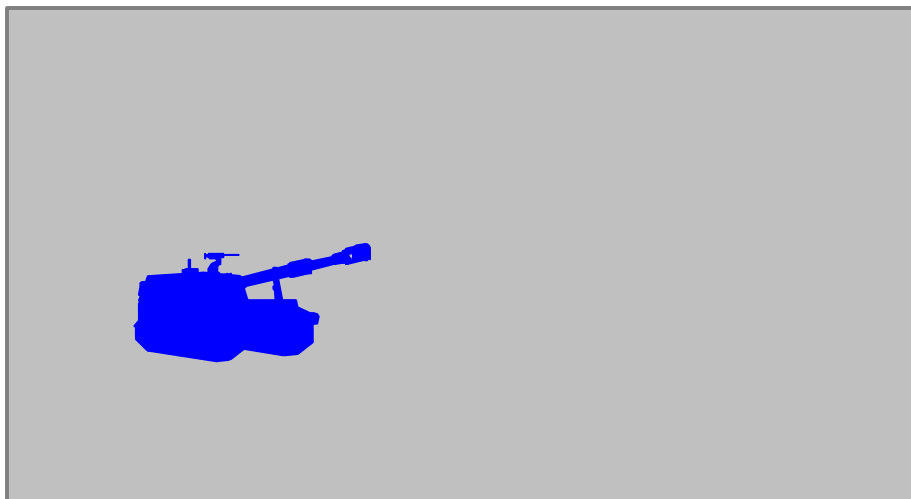

DEPLOY	START	ADMIN				
GROUP	1 2 3 4 5					
	6 7 8 9 10					
RE-ORG	001	FORCE	001			
COUNTER	00000 .00					
TIMER	00:00:00:00					
GR99A	PP	02000	87001			
RTE	ALT	DEL	CAN	COPY		
I	STOP/GO	HALT	Go			
MOVE	SHOW	SPEED	MAXIMUM			
MOUNT	TRANSFER		ASSIGN			
DISMNT	LINE-F	DEFL	PIT			
VIEW	FORWARD	LOS	FACE			
IC	GP	FM	FC	SD		
ROE	HOLD	SMOKE	GRENADE			
LOSSBS	TRACKER		OPFOR			
INFO	DATA		DETECT			
	MISC		ISR			
DFIR	FORM	SOP	URBAN			
IFIR	AYN	ENG	LOG			
PLN	ALT	EOM	C/F			
ADJ	TIME		PRI			
	HE	CONV				
	006 RFFE, FB Rate					
	002 For 010 Mins					
	LRP		DF			
ICRPT	IFRPT	INFO				
Zm	Df	1	2	3	4	5
PREV	NEXT	PAN		GRID		
CLOS	FROB	ENMY	HULK	Obs		
CLEAR	UP	DN	PRINT			

QUESTIONS?

SET
IMPACT POINT

IFIR SET IMPACT POINT

Option 1 - Use cursor

Select **IFIR**.

Select **PLN**.

Click on the Impact Point - Icon or terrain.

Impact Point indicator appears at cursor location

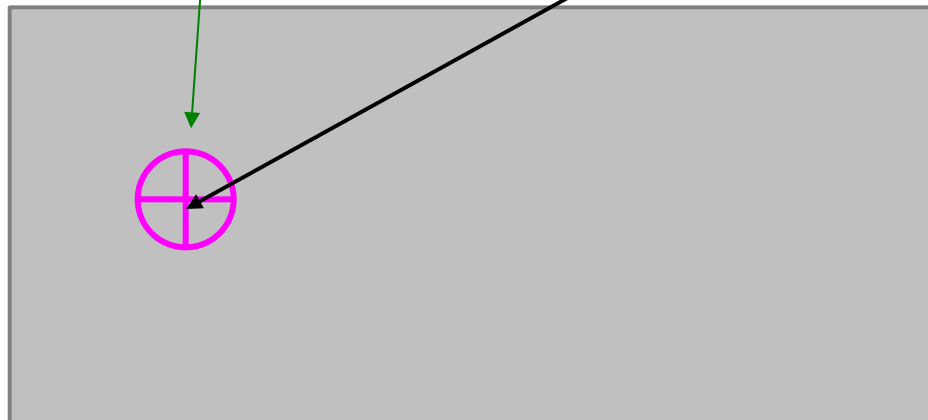

DEPLOY	START	ADMIN				
GROUP	1 2 3 4 5					
	6 7 8 9 10					
RE-ORG	001	FORCE	001			
COUNTER	00000.00					
TIMER	00:00:00:00					
GR99A	PP	02000	87001			
RTE	ALT	DEL	CAN	COPY		
ISTOP/GO	HALT		Go			
MOVE	SHOW	SPEED	MAXIMUM			
MOUNT	TRANSFER		ASSIGN			
DISMNT	LINE-F	DEFL	PIT			
VIEW	FORWARD	LOS	FACE			
IC	GP	FM	FC	SD		
RDE	HOLD	SMOKE	GRENADE			
LOSSBS	TRACKER		OPFOR			
INFO	DATA		DETECT			
	MISC	ISR				
DFIR	FORM	SOP	URBAN			
IFIR	AYN	ENG	LOG			
PLN	ALT	EOM	C/F			
ADJ	TIME		PRI			
	HE		CONV			
	006 RFFE, FB Rate					
	000 For 000 Mins					
	LRP		DF			
ICRPT	IFRPT	INFO				
L						
ZM	DF	1	2	3	4	5
PREV	NEXT		PAN	GRID		
CLOS	FRDS	ENMY	HULK	OBS		
CLEAR	UP	DN	PRINT			

IFIR

SET IMPACT POINT

Option 2 - Use GR Counter

First, set **Impact Point** Grid Reference on GR counter:

[either Toggle or **GR** **Y**]

Select **IFIR**.

Select **PLN**.

Impact Point indicator appears at Grid Reference set on GR counter.

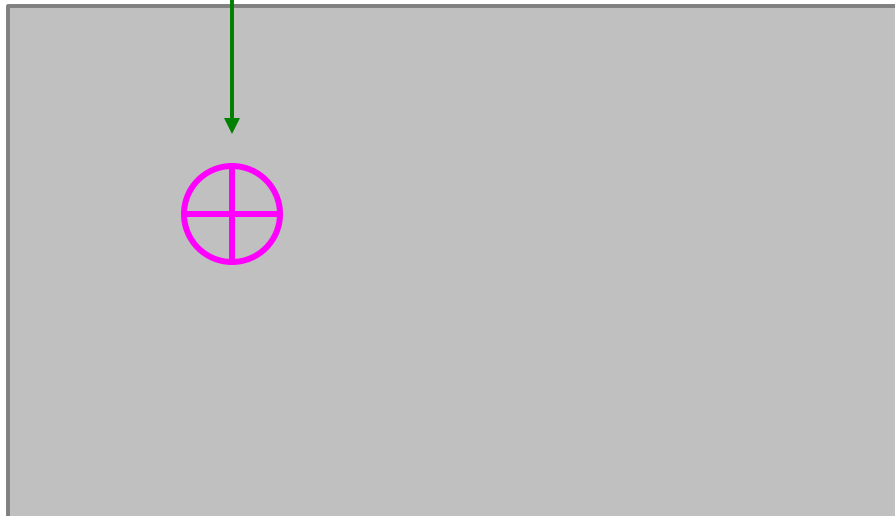

DEPLOY	START	ADMIN				
GROUP	1 2 3 4 5					
	6 7 8 9 10					
RE-ORG	001	FORCE	001			
COUNTER	00000.00					
TIMER	00:00:00:00					
GR99A	PP	02000	87001			
RTE	ALT	DEL	CAN	COPY		
ISTOP/GO	HALT		GO			
MOVE	SHOW	SPEED	MAXIMUM			
MOUNT	TRANSFER		ASSIGN			
DISMNT	LINE-F	DEFL	PIT			
VIEW	FORWARD	LOS	FACE			
IC	GP	FM	FC	SD		
ROE	HOLD	SMOKE	GRENADE			
LOGSBS	TRACKER	OPFOR				
INFO	DATA	DETECT				
	MISC	ISR				
DFIR	FORM	SOP	URBAN			
IFIR	AYN	ENG	LOG			
PLN	ALT	EOM	C/F			
ADJ	TIME		PRI			
	HE	CONV				
	006 RFFE, FB Rate					
	000 For 000 Mins					
	LRP	DF				
ICRPT	IFRPT	INFO				
ZM	DF	1	2	3	4	5
PREV	NEXT	PAN		GRID		
CLDS	FRDS	ENMY	HULK	OBS		
CLEAR	UP	DN	PRINT			



IFIR

SET IMPACT POINT

Option 3 – Use DF

Set counter to **DF #**



Select **PLN.**



Impact Point indicator appears at location of DF set on counter.

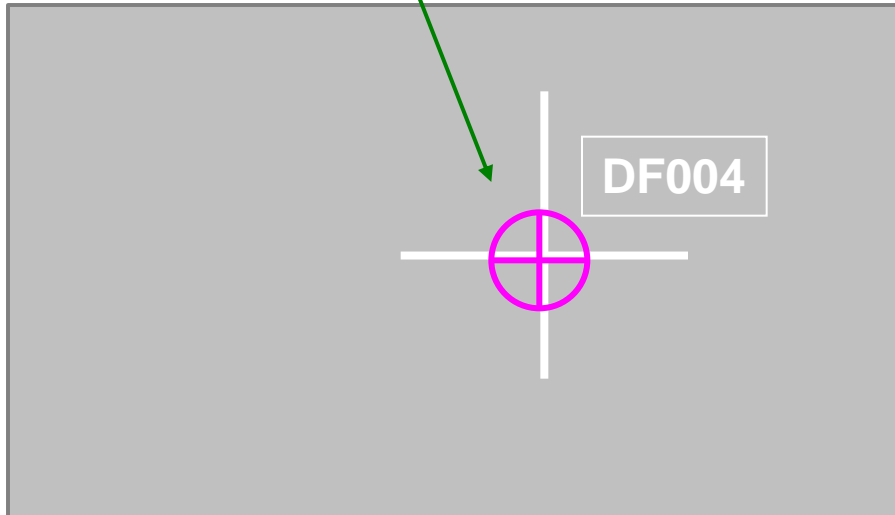

DEPLOY	START	ADMIN		
GROUP	1 2 3 4 5			
	6 7 8 9 10			
RE-ORG	001	FORCE	001	
COUNTER	00004	.	00	
TIMER	00:00:00:00			
GR99A	PP	02000	87001	
RTE	ALT	DEL	CAN	COPY
I	STOP/GD	HALT		GO
MOVE	SHOW	SPEED		MAXIMUM
MOUNT		TRANSFER		ASSIGN
DISMNT	LINE-F	DEFL		PIT
VIEW	FORWARD	LOS		FACE
IC	GP	FM	FC	SD
ROE	HOLD	SMOKE		GRENADE
LOSSES		TRACKER		OPFOR
INFO		DATA		DETECT
		MISC		ISR
DFIR		FORM		SOP
		URBAN		
IFIR		AYN		ENG
		LOG		
PLN		ALT		EOM
		C/F		
ADJ		TIME		PRI
		HE		CONV
		006		RFFE, FB Rate
		000		For 000 Mins
		LRP		DF
ICRPT		IFRPT		INFO
Zm		DF		1 2 3 4 5
PREV		NEXT		PAN GRID
CLOS		F RDS		ENMY HULK OBS
CLEAR		UP		DN PRINT

IFIR

AREA Impact Pattern

Select **IFIR**.



Toggle to **AREA** option.



 Click on the Impact Point centre point

Click to set Impact Point radius

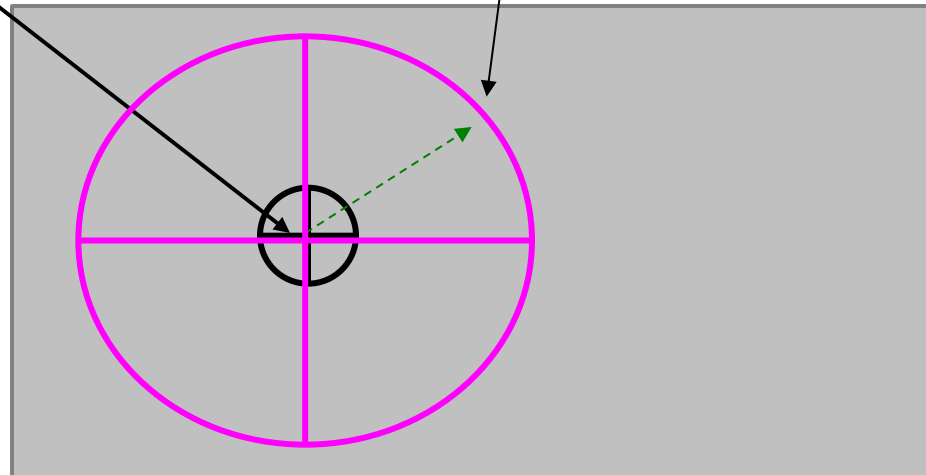

IFIR

LINEAR Impact Pattern

Select **IFIR**.



Toggle to **LINEAR** option.



Y Click to set end point

Click to set other end point

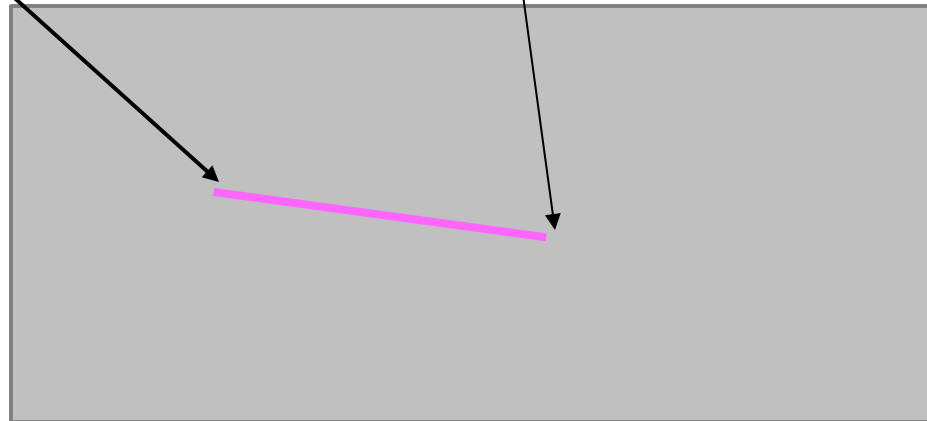

QUESTIONS?

**SELECT
FIRE UNIT(S)**

INDIRECT FIRE SELECT FIRE UNIT

Individual Fire Unit Icon

Set Scope to Icon

Click on a single fire unit icon to apply the mission details to that fire unit icon.

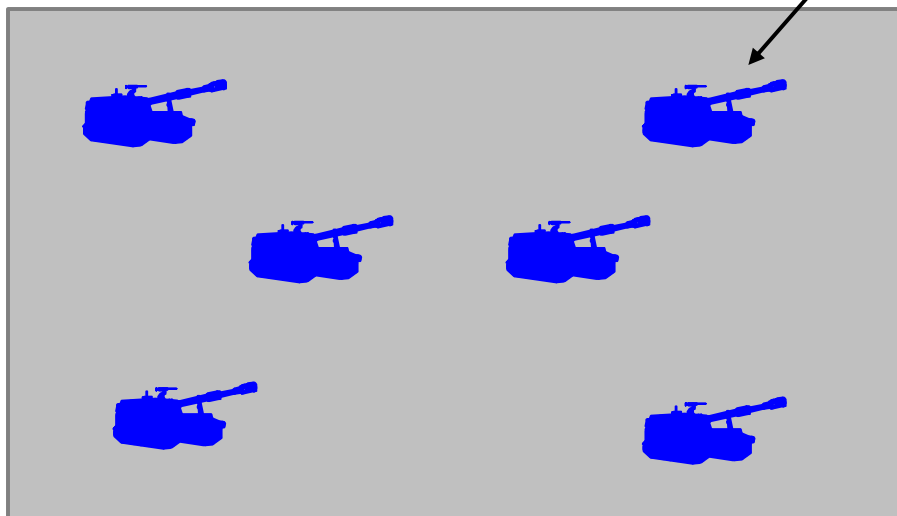

DEPLOY	START	ADMIN		
GROUP	1 2 3 4 5			
	6 7 8 9 10			
RE-ORG	001	FORCE	001	
COUNTER	00000.00			
TIMER	00:00:00:00			
GR99A	PP	02000	87001	
RTE	ALT	DEL	CAN	COPY
ISTOP/GO		HALT		Go
MOVE	SHOW	SPEED	MAXIMUM	
MOUNT	TRANSFER		ASSIGN	
DISMNT	LINE-F	DEFL	PIT	
VIEW	FORWARD	LOS	FACE	
IC	GP	FM	FC	SD
ROE	HOLD	SMOKE	GRENADE	
LOSSBS	TRACKER		OPFOR	
INFO	DATA		DETECT	
	Misc	ISR		
DFIR	FORM	SOP	URBAN	
IFIR	AYN	ENG	LOG	
PLN	ALT	EOM	C/F	
ADJ	TIME		PRI	
	HE	CONV		
	006RFFE, FB Rate			
	000For 000Mins			
	LRP		DF	
ICRPT	IFRPT	INFO		
L				
ZM	DF	1	2	3 4 5
PREV	NEXT	PAN		GRID
CLOS	FROB	ENMY	HULK	Obs
CLEAR	UP	DN	PRINT	

INDIRECT FIRE SELECT FIRE UNIT

Select all fire unit icons in a Group or Force

Select appropriate Group

Set Scope to **Group** or **Force**.

Y

Click on a fire unit icon to apply the mission details to all fire unit icons in the selected Group or Force.

B

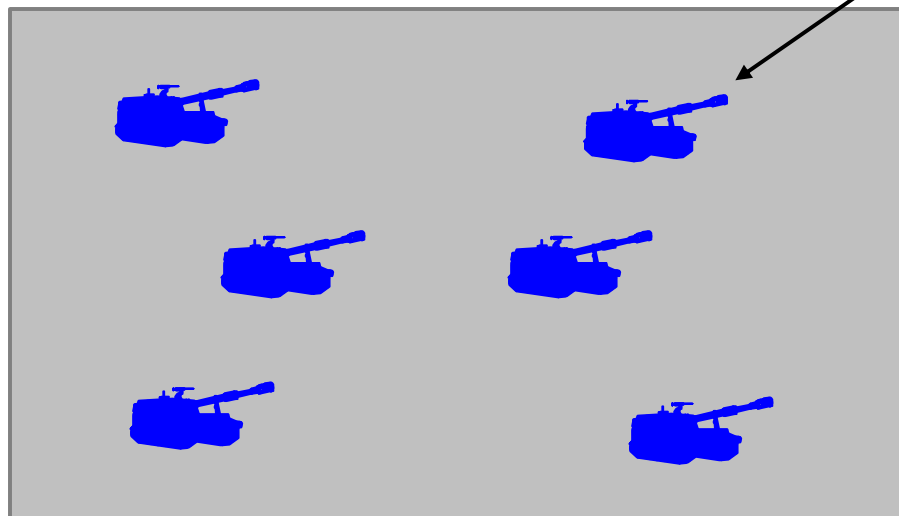

DEPLOY	START	ADMIN				
GROUP	1 2 3 4 5	6 7 8 9 10				
RE-ORG	001	FORCE	001			
COUNTER	00000.00					
TIMER	00:00:00:00					
GR99A	PP	02000	87001			
RTE	ALT	DEL	CAN	COPY		
I STOP/GO		HALT		GO		
MOVE	SHOW	SPEED	MAXIMUM			
MOUNT	TRANSFER		ASSIGN			
DISMNT	LINE-F	DEFL	PIT			
VIEW	FORWARD	LOS	FACE			
IG	GP	FM	FC	SD		
ROE	HOLD	SMOKE	GRENADE			
LOGS	TRACKER		OFFOR			
INFO	DATA		DETECT			
		MISC	ISR			
DFIR	FORM	SOP	URBAN			
IFIR	AYN	ENG	LOG			
PLN	ALT	EOM	C/F			
ADJ	TIME		PRI			
		HE	CONV			
006 RFFE, FB Rate						
000 For 000 Mins						
		LRP	DF			
ICRPT	IFRPT	INFO				
Zm	DF	1	2	3	4 5	
PREV	NEXT	PAN		GRID		
CLDS	FRDS	ENMY	HULK	DBS		
CLEAR	UP	DN	PRINT			

QUESTIONS?

**MODIFY
A
MISSION**

IFIR DISPLAY RANGE RINGS

Select **ammunition type**



Click on **ALT**



Click on **Icon**

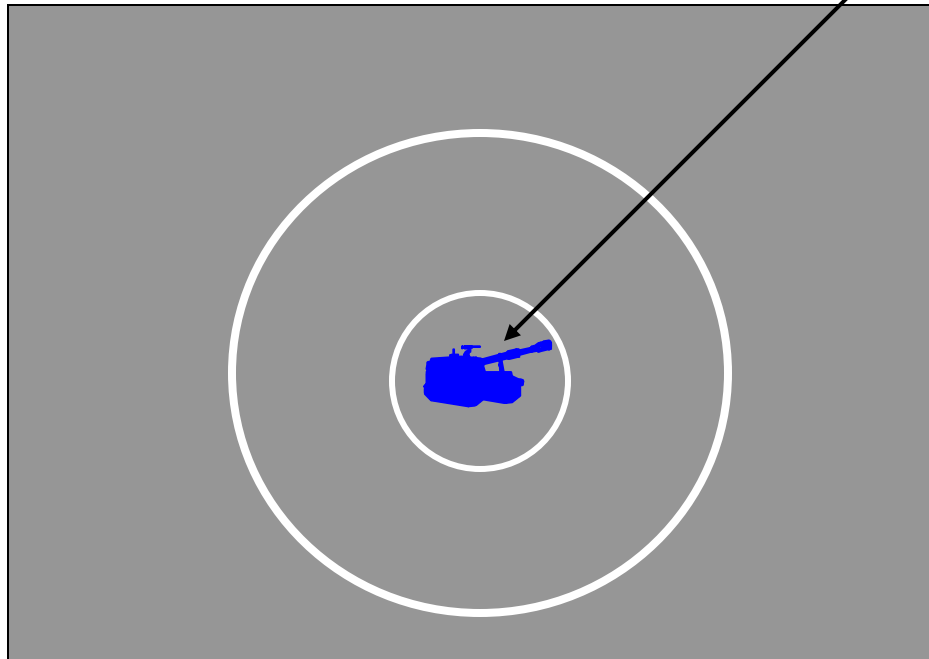

DEPLOY	START	ADMIN		
GROUP	1 2 3 4 5			
	6 7 8 9 10			
RE-ORG	001	FORCE	001	
COUNTER	00000	.00		
TIMER	00:00:00	:00		
GR99A	PP 02000	87001		
RTE	ALT	DEL	CAN	COPY
ISTOP/GD	HALT		GO	
MOVE	SHOW	SPEED	MAXIMUM	
MOUNT		TRANSFER	ASSIGN	
DISMNT	LINE-F	DEFL	PIT	
VIEW	FORWARD	LOS	FACE	
IC	GP	FM	FC	SD
ROE	HOLD	SMOKE	GRENADE	
LOSSES	TRACKER	OPFOR		
INFO	DATA		DETECT	
	MISC	ISR		
DFIR	FORM	SOP	URBAN	
IFIR	AYN	ENG	LOG	
PLN	ALT	EOM	C/F	
ADJ	TIME	PRI		
	HE	CONV		
	000RFFE, FB	Rate		
	000For	000Mins		
	LRP	DF		
ICRPT	IFRPT	INFO		
Zm	DF	1 2 3 4 5		
PREV	NEXT	PAN	GRID	
CLDS	FRDS	ENMY	HULK	DBS
CLEAR	UP	DN	PRINT	

IFIR

ALTER MISSION

Click on **IFIR**.
Click on **ALT**.

Click on fire unit - planned missions
are shown with a white dotted line.
Click on Impact Point to be altered.
Click on the new Impact Point.

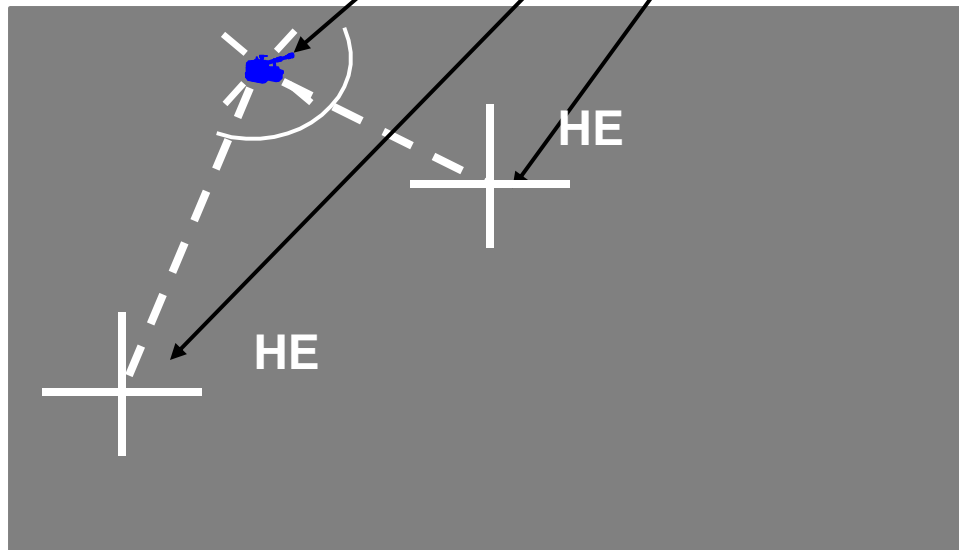

DEPLOY	START	ADMIN		
GROUP	1 2 3 4 5			
	6 7 8 9 10			
RE-ORG	001	FORCE	001	
COUNTER	00000	.	00	
TIMER	00:00:00	:	00	:
		:	00	:
GR99A	PP 02000	87001		
RTE	ALT	DEL	CAN	COPY
ISTOP/GD	HALT		GD	
MOVE	SHOW	SPEED		MAXIMUM
MOUNT		TRANSFER		ASSIGN
DISMNT	LINE-F	DEFL		PIT
VIEW	FORWARD	LOS		FACE
IC	GP	FM	FC	SD
ROE	HOLD	SMOKE		GRENADE
LOGSBS		TRACKER		OPFOR
INFO		DATA		DETECT
		MISC		ISR
DFIR	FORM	SOP		URBAN
IFIR	AYN	ENG		LOG
PLN	ALT	EOM		C/F
ADJ		TIME		PRI
		HE		CONV
	000	RFFE, FB		Rate
	000	For		000 Mins
		LRP		DF
ICRPT	IFRPT			INFO
Zm	DF	1	2	3
		4	5	
PREV		NEXT		PAN GRID
CLDS	FRDS	ENMY		HULK OBS
CLEAR	UP	DN		PRINT

IFIR Check Fire

Click on **IFIR**



Click on **C/F**



Status will display on those icons set to 'checkfire'

Toggle C/F On/Off

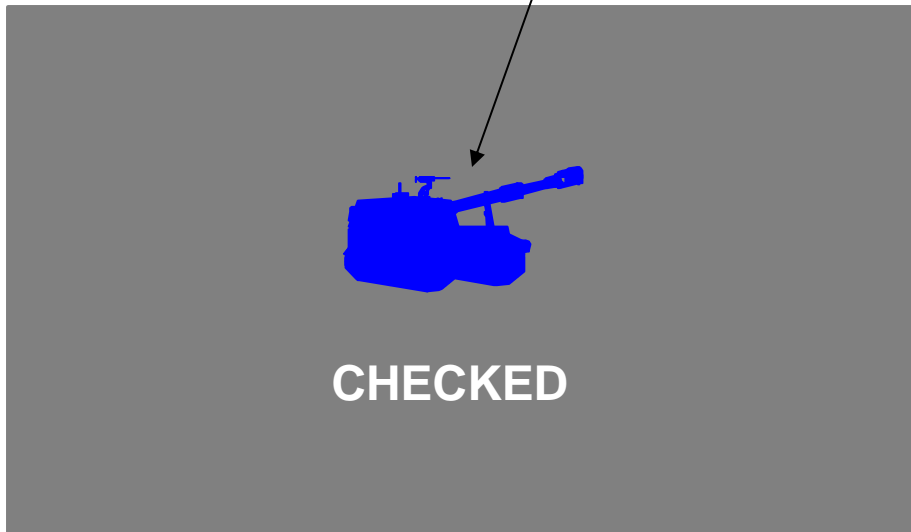

DEPLOY	START	ADMIN		
GROUP	1 2 3 4 5			
	6 7 8 9 10			
RE-ORG	001	FORCE	001	
COUNTER	00000 .00			
TIMER	00:00:00:00			
GR99A	PP	02000	87001	
RTE	ALT	DEL	CAN	COPY
ISTOP/GD	HALT	Go		
MOVE	SHOW	SPEED	MAXIMUM	
MOUNT	TRANSFER		ASSIGN	
DISMNT	LINE-F	DEFL	PIT	
VIEW	FORWARD	LOS	FACE	
IC	GP	FM	FC	SD
ROE	HOLD	SMOKE	GRENADE	
LOSSBS	TRACKER	OPFOR		
INFO	DATA	DETECT		
	MISC	ISR		
DFIR	FORM	SOP	URBAN	
IFIR	AYN	ENG	LOG	
PLN	ALT	EOM	C/F	
ADJ	TIME	PRI		
	HE	CONV		
	000 RFFE, FB Rate			
	000 For 000 Mins			
	LRP	DF		
ICRPT	IFRPT	INFO		
L				
Zm	DF	1	2	3 4 5
PREV	NEXT	PAN	GRID	
CLDS	FRDS	ENMY	HULK	Obs
CLEAR	UP	DN	PRINT	

IFIR

END of MISSION

Click on **IFIR**



Click on **EOM**



Click on icon.



Click on Impact Point.

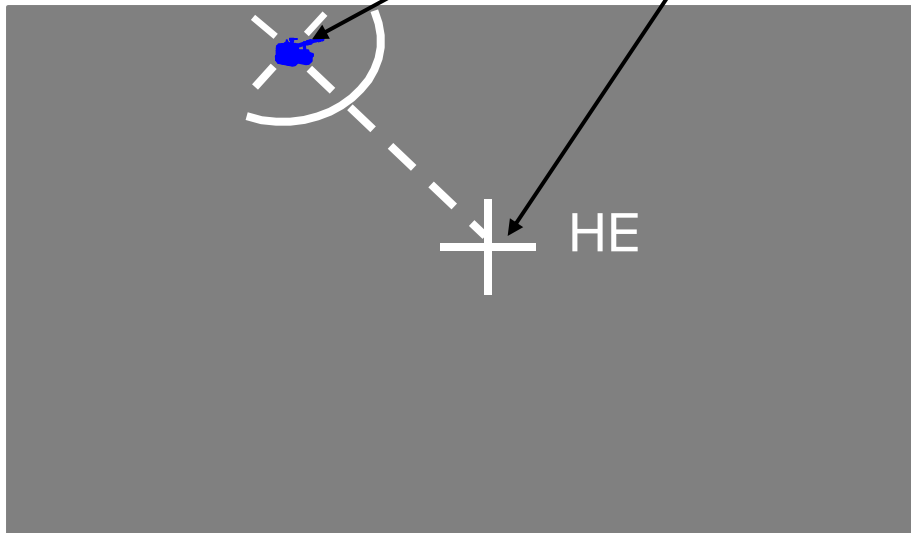

DEPLOY	START	ADMIN			
GROUP	1 2 3 4 5				
	6 7 8 9 10				
RE-ORG	001	FORCE	001		
COUNTER	00000	.	00		
TIMER	00:00:00:00				
GR99A	PP 02000	87001			
RTE	ALT	DEL	CAN	COPY	
I	STOP/GO	HALT		GO	
MOVE	SHOW	SPEED		MAXIMUM	
MOUNT		TRANSFER		ASSIGN	
DISMNT	LINE-F	DEFL		PIT	
VIEW	FORWARD	LOS		FACE	
IC	GP	FM	FC	SD	
ROE	HOLD	SMOKE		GRENADE	
LOSSBS		TRACKER		OPFOR	
INFO		DATA		DETECT	
		MISC		ISR	
DFIR	FIRM	SOP		URBAN	
IFIR	AYN	ENG		LOG	
PLN	ALT	EOM		C/F	
ADJ		TIME		PRI	
		HE		CONV	
		000RFFE, FB		Rate	
		000For 000		Mins	
		LRP		DF	
ICRPT	IFRPT			INFO	
Zm	DF	1	2	3	4
		5			
PREV		NEXT		PAN	GRID
CLOS	FROB	ENRY	HULK	OBG	
CLEAR	UP	DN		PRINT	

IFIR

End All Missions

Click on **IFIR**



Click on **EOM**



Click on icon.



Cancels all IF missions including those being fired

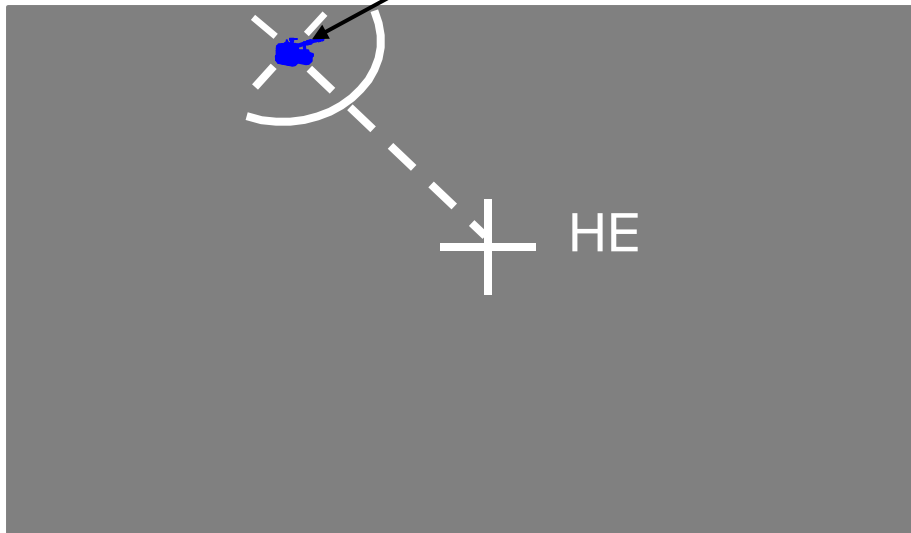

DEPLOY	START	ADMIN		
GROUP	1 2 3 4 5			
	6 7 8 9 10			
RE-ORG	001	FORCE	001	
COUNTER	00000	.	00	
TIMER	00:00:00:00			
GR99A	PP 02000	87001		
RTE	ALT	DEL	CAN	COPY
I	STOP/GO	HALT		GO
MOVE	SHOW	SPEED		MAXIMUM
MOUNT		TRANSFER		ASSIGN
DISMNT	LINE-F	DEFL		PIT
VIEW	FORWARD	LOS		FACE
IC	GP	FM	FC	SD
ROE	HOLD	SMOKE		GRENADE
LOSSBS		TRACKER		OPFOR
INFO		DATA		DETECT
		MISC		ISR
DFIR	FIRM	SOP		URBAN
IFIR	AYN	ENG		LOG
PLN	ALT	EOM		C/F
ADJ		TIME		PRI
		HE		CONV
		000RFFE, FB		Rate
		000For 000		Mins
		LRP		DF
ICRPT	IFRPT			INFO
Zm	DF	1	2	3 4 5
PREV		NEXT		PAN GRID
CLDS	FROB	ENRY	HULK	Obs
CLEAR	UP	DN		PRINT

MISSION REPORTS

IFIR

IFIR Missions Report (IFRPT)

All current executing missions for the force



All missions for the selected scope setting

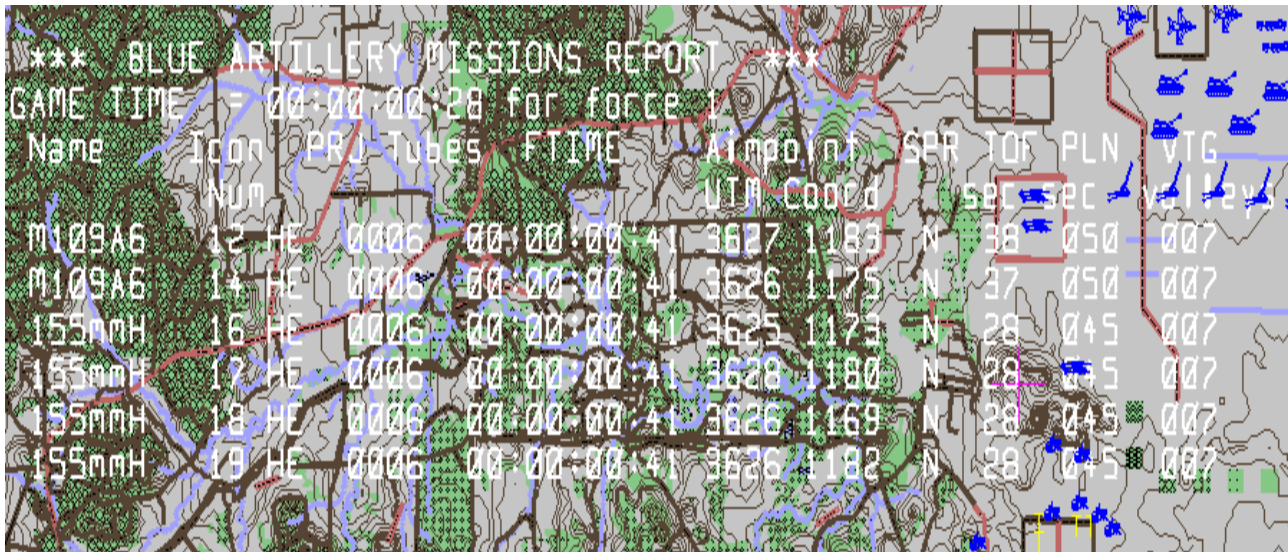

DEPLOY	ADMIN										
GROUP	1	2	3	4	5	6	7	8	9	10	
RE-ORG	001	FORCE				001					
COUNTER	00000.00										
TIMER	00:00:00:00										
GR99A	PP	02000	87001								
RTE	ALT	DEL	CAN	COPY							
ISTOP/GO	HALT			Go							
MOVE	SHOW	SPEED	MAXIMUM								
MOUNT	TRANSFER		ASSIGN								
DISMNT	LINE-F	DEFL	PIT								
VIEW	FORWARD		LOS FACE								
IC	GP	FM	FC	SD							
ROE	HOLD	SMOKE	GRENADE								
LOSSES	TRACKER		OPFOR								
INFO	DATA		DETECT								
		MISC	ISR								
DFIR	FORM	SOP	URBAN								
IFIR	AYN	ENG	LOG								
PLN	ALT	EDM	C/F								
ADJ	TIME		PRI								
		HE	CONV								
		000	RFFE, FB Rate								
		000	For 000 Mins								
		LRP	DF								
ICRPT	IFRPT	INFO									

Zm	DF	1	2	3	4	5					
PREV	NEXT	PAN		GRID							
CLDS	FRDS	ENMY	HULK	Obs							
CLEAR	UP	DN	PRINT								
00:00:00:12											

IFIR

IFIR Missions Report

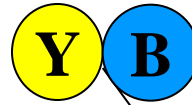

Name	Icon Num	PRJ	Tubes	FTime	Aimpoint UTM COORD	SPR	TOF	PLN	Rounds to go
------	----------	-----	-------	-------	-----------------------	-----	-----	-----	-----------------

EXPLANATION

Name	Icon/Weapon type
Icon Num	ID Number
PRJ	Type of projectile
Tubes	Number of aggregated weapon systems
FTime	Game time of the next mission volley or CHECKED if Checkfire imposed.
Aimpoint	UTM Grid co-ordinates
SPR	Whether or not the unit is suppressed (Y = suppressed)
TOF	Time of Flight (seconds) from next firing until impact
PLN	Planning Time (seconds) between the request for fire and the firing of the first volley
Rounds to go	Number of Rounds to go to complete the mission

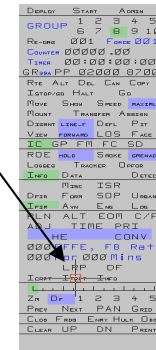

MISSION SUMMARY

Click on **IFIR**



Click on **Icrpt**



Click on icon

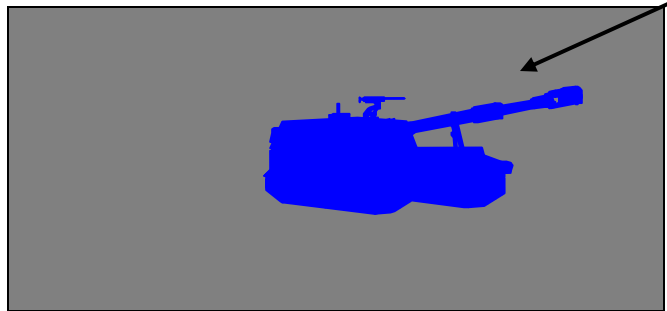

Unit number 18 Numb of elements 6
 Next searched msn: 2 Next timed msn: 1 at time =00:00:00:00

-Msn-	-Pri-	-Tim-	-Seq-	-Prj-	-Shf-	-Vols-
2	S	00:00:01:21	2	HE	L	5
3	S	00:00:00:00	3	HE	L	6
4	S	00:00:00:00	4	HE	L	8
4	S	00:00:00:00	4	HE	L	4

DEPLOY	START	ADMIN		
GROUP	1 2 3 4 5			
	6 7 8 9 10			
RE-ORG	001	FORCE	001	
COUNTER	00000		.00	
TIMER	00:00:00:00			
GR99A	PP 02000		87001	
RTE	ALT	DEL	CAN	COPY
ISTOP/GD	HALT		GO	
MOVE	SHOW	SPEED		MAXIMUM
MOUNT		TRANSFER		ASSIGN
DISMNT	LINE-F	DEFL		PIT
VIEW	FORWARD	LOS		FACE
IC	GP	FM	FC	SD
ROE	HOLD	SMOKE		GRENADE
LOGSBS		TRACKER		OPFOR
INFO	DATA			DETECT
	MISC	ISR		
DFIR	FORM	SOP		URBAN
IFIR	AYN	ENG		LOG
PLN	ALT	EOM		C/F
ADJ	TIME	PRI		
	HE	CONV		
	005	RFFE, FB		Rate
	000	For		000 Mins
		LRP		DF
Icrpt	Ifrpt			INFO
Zm	DF	1 2 3 4 5		
PREV	NEXT	PAN		GRID
CLDS	FRDS	ENMY		HULK OBS
CLEAR	UP	DN		PRINT

QUESTIONS?

DEFENSIVE FIRE

IFIR

Defensive Fire

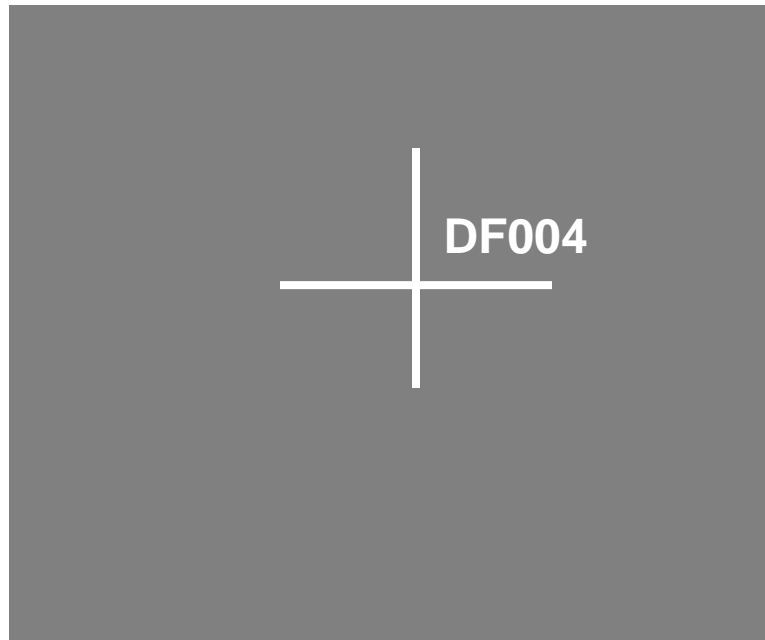

DF

Create DF

Click on **IFIR**.



Click on **DF**.



Click on the target - Icon or terrain.

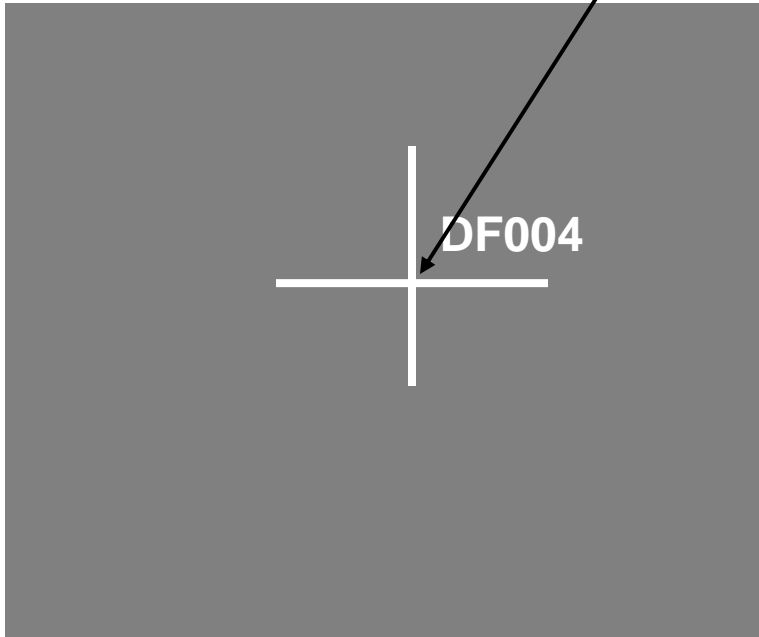

DEPLOY	START	ADMIN				
GROUP	1 2 3 4 5					
	6 7 8 9 10					
RE-ORG	001	FORCE	001			
COUNTER	00000 .00					
TIMER	00:00:00:00					
GR99A	PP	02000	87001			
RTE	ALT	DEL	CAN	COPY		
ISTOP/GD	HALT		GD			
MOVE	SHOW	SPEED	MAXIMUM			
MOUNT	TRANSFER		ASSIGN			
DISMNT	LINE-F	DEFL	PIT			
VIEW	FORWARD	LOS	FACE			
IC	GP	FM	FC	SD		
ROE	HOLD	SMOKE	GRENADE			
LOGSES	TRACKER		OPFOR			
INFO	DATA		DETECT			
	MISC	ISR				
DFIR	FORM	SOP	URBAN			
IFIR	AYN	ENG	LOG			
PLN	ALT	EOM	C/F			
ADJ	TIME		PRI			
	HE	CONV				
	000RFFE,	FB	Rate			
	000For	000Mins				
	LRP	DF				
ICRPT	IFRPT	INFO				
Zm	DF	1	2	3	4	5
PREV	NEXT	PAN		GRID		
CLDS	F RDS	ENMY	HULK	Obs		
CLEAR	UP	DN	PRINT			

DF

Delete DF

Click on **IFIR**.



Click on **DF**.



Click on the DF to be removed

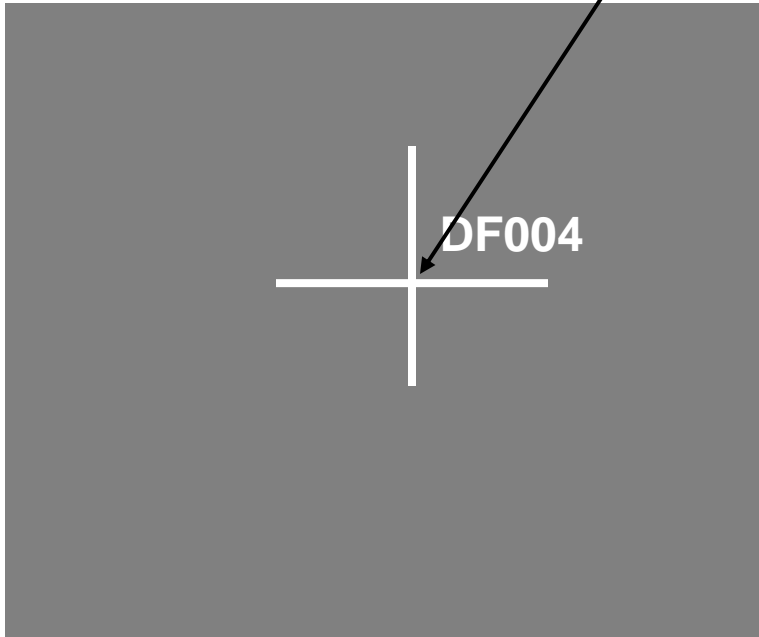

DEPLOY	START	ADMIN				
GROUP	1 2 3 4 5					
	6 7 8 9 10					
RE-ORG	001	FORCE	001			
COUNTER	00000 .00					
TIMER	00:00:00:00					
GR99A	PP	02000	87001			
RTE	ALT	DEL	CAN	COPY		
ISTOP/GD	HALT		GD			
MOVE	SHOW	SPEED	MAXIMUM			
MOUNT	TRANSFER		ASSIGN			
DISMNT	LINE-F	DEFL	PIT			
VIEW	FORWARD	LOS	FACE			
IC	GP	FM	FC	SD		
ROE	HOLD	SMOKE	GRENADE			
LOGSES	TRACKER		OPFOR			
INFO	DATA		DETECT			
	MISC	ISR				
DFIR	FORM	SOP	URBAN			
IFIR	AYN	ENG	LOG			
PLN	ALT	EOM	C/F			
ADJ	TIME		PRI			
	HE	CONV				
	000RFFE, FB Rate					
	000For 000Mins					
	LRP	DF				
ICRPT	IFRPT	INFO				
	L					
Zm	DF	1	2	3	4	5
PREV	NEXT	PAN		GRID		
CLDS	FRDS	ENMY	HULK	OBS		
CLEAR	UP	DN	PRINT			

LASER REGISTRATION

IFIR

Laser Registration Point

LRP

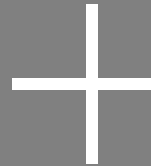

LRP

Create LRP

Click on IFIR. 

Click on LRP. 

Click on the LRP point - Icon or terrain. 

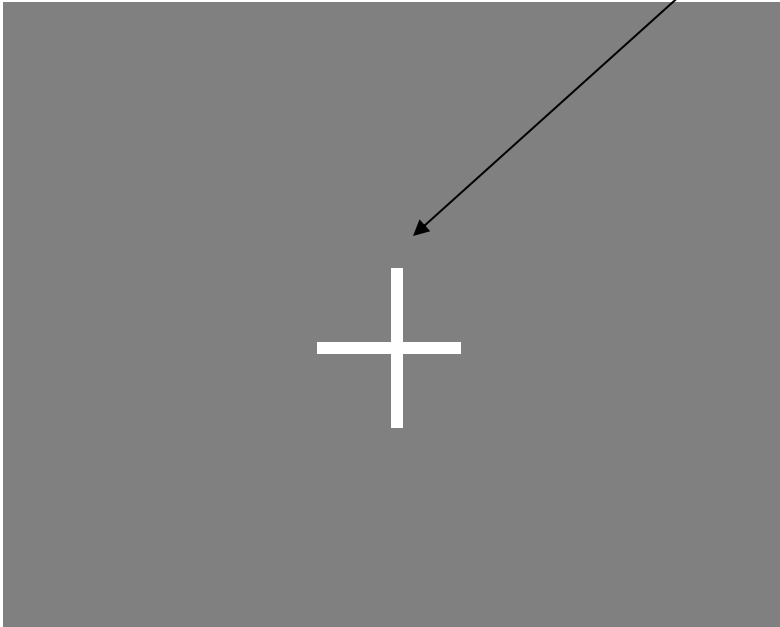

DEPLOY	START	ADMIN			
GROUP	1 2 3 4 5				
	6 7 8 9 10				
RE-ORG	001	FORCE	001		
COUNTER	00000.00				
TIMER	00:00:00:00				
GR99A	PP 02000	87001			
RTE	ALT	DEL	CAN	COPY	
I	STOP/GO	HALT		Go	
MOVE	SHOW	SPEED		MAXIMUM	
MOUNT		TRANSFER		ASSIGN	
DISMNT	LINE-F	DEFL		PIT	
VIEW	FORWARD	LOS		FACE	
IC	GP	FM	FC	SD	
ROE	HOLD	SMOKE		GRENADE	
LOSSES		TRACKER		OPFOR	
INFO		DATA		DETECT	
	Misc	ISR			
DFIR	FORM	SOP		URBAN	
IFIR	AYN	ENG		LOG	
PLN	ALT	EOM		C/F	
ADJ		TIME		PRI	
	HE			CONV	
	000RFFE,			FB Rate	
	000For			000Mins	
		LRP		DF	
ICRPT	IFRPT			INFO	
	L				
ZM	Df	1	2	3	4
		5			
PREV		NEXT		PAN	GRID
CLOS	FROB			ENMY	HULK
				Obs	
CLEAR		UP		DN	PRINT

LRP

Delete LRP

Click on **IFIR**. 

Click on **LRP**. 

Click on the LRP symbol to be removed. 

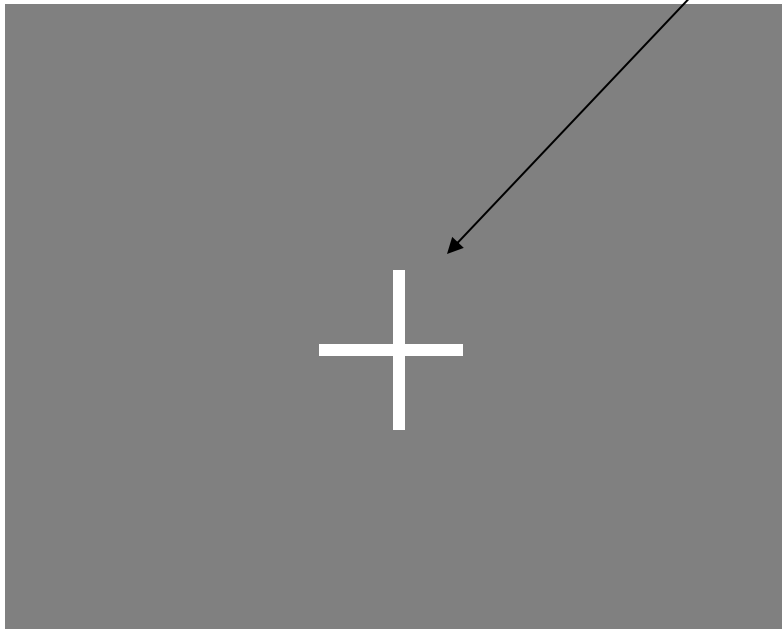

DEPLOY	START	ADMIN		
GROUP	1 2 3 4 5			
	6 7 8 9 10			
RE-ORG	001	FORCE	001	
COUNTER	00000.00			
TIMER	00:00:00:00			
GR99A	PP	02000	87001	
RTE	ALT	DEL	CAN	COPY
ISTOP/GO	HALT		Go	
MOVE	SHOW	SPEED	MAXIMUM	
MOUNT	TRANSFER		ASSIGN	
DISMNT	LINE-F	DEFL	PIT	
VIEW	FORWARD	LOS	FACE	
IC	GP	FM	FC	SD
ROE	HOLD	SMOKE	GRENADE	
LOGSBS	TRACKER		OPFOR	
INFO	DATA		DETECT	
	Misc	ISR		
DFIR	FORM	SOP	URBAN	
IFIR	AYN	ENG	LOG	
PLN	ALT	EOM	C/F	
ADJ	TIME		PRI	
	HE	CONV		
000RFFE, FB Rate				
000For 000 Mins				
	LRP	DF		
ICRPT	IFRPT	INFO		
L				
ZM	DF	1	2	3 4 5
PREV	NEXT	PAN		GRID
CLOS	FROB	ENMY	HULK	Obs
CLEAR	UP	DN	PRINT	

**FINAL
PROTECTIVE
FIRE**

LRP LAY ON

Click on **IFIR**



Click on **LRP**



Click on **ICON**



Click on Point of Interest

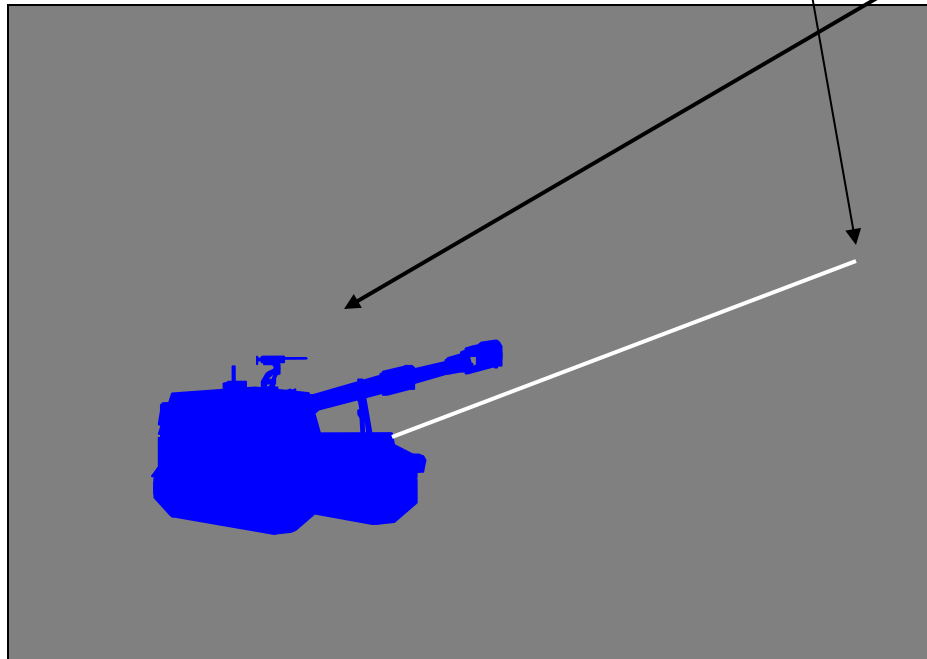

DEPLOY	START	ADMIN		
GROUP	1 2 3 4 5			
	6 7 8 9 10			
RE-ORG	001	FORCE	001	
COUNTER	00000.00			
TIMER	00:00:00:00			
GR99A	PP	02000	87001	
RTE	ALT	DEL	CAN	COPY
ISTOP/GO	HALT		Go	
MOVE	SHOW	SPEED	MAXIMUM	
MOUNT	TRANSFER		ASSIGN	
DISMNT	LINE-F	DEFL	PIT	
VIEW	FORWARD	LOS	FACE	
IC	GP	FM	FC	SD
ROE	HOLD	SMOKE	GRENADE	
LOSSBS	TRACKER		OPFOR	
INFO	DATA		DETECT	
	Misc	ISR		
DFIR	FORM	SOP	URBAN	
IFIR	AYN	ENG	LOG	
PLN	ALT	EOM	C/F	
ADJ	TIME		PRI	
	HE	CONV		
	000RFFE, FB Rate			
	000For 000Mins			
	LRP	DF		
ICRPT	IFRPT	INFO		
ZM	DF	1	2	3 4 5
PREV	NEXT	PAN		GRID
CLOS	FROB	ENMY	HULK	Obs
CLEAR	UP	DN	PRINT	

LRP

Cancel LAY ON

Click on **IFIR**

Click on **LRP**

Click on **ICON**

Click on Terrain display

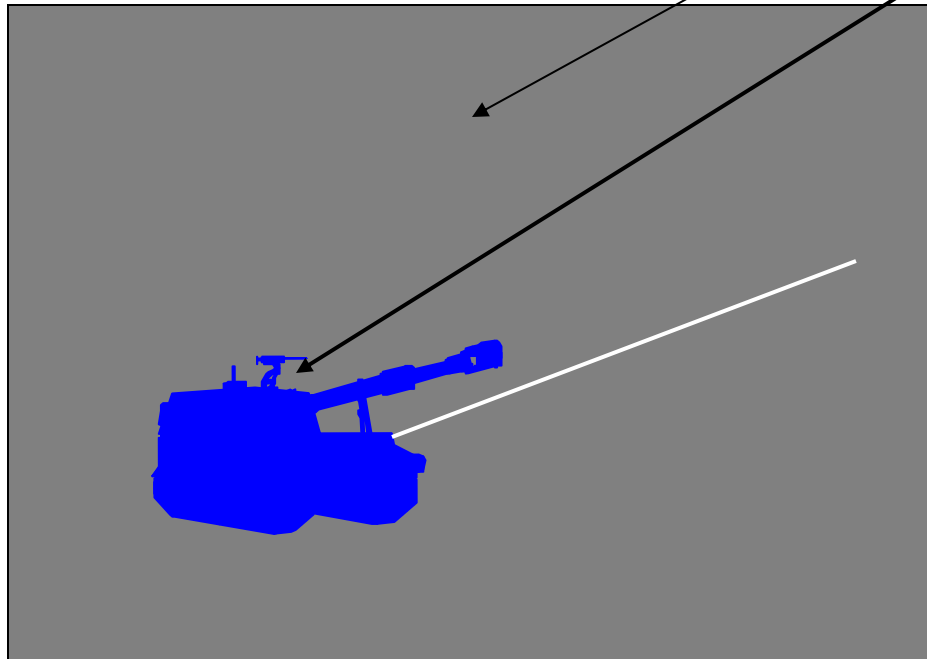

DEPLOY	START	ADMIN		
GROUP	1 2 3 4 5			
	6 7 8 9 10			
RE-ORG	001	FORCE	001	
COUNTER	00000.00			
TIMER	00:00:00:00			
GR99A	PP	02000	87001	
RTE	ALT	DEL	CAN	COPY
ISTOP/GO	HALT		Go	
MOVE	SHOW	SPEED	MAXIMUM	
MOUNT	TRANSFER		ASSIGN	
DISMNT	LINE-F	DEFL	PIT	
VIEW	FORWARD	LOS	FACE	
IC	GP	FM	FC	SD
ROE	HOLD	SMOKE	GRENADE	
LOSSBS	TRACKER		OPFOR	
INFO	DATA		DETECT	
	Misc	ISR		
DFIR	FORM	SOP	URBAN	
IFIR	AYN	ENG	LOG	
PLN	ALT	EOM	C/F	
ADJ	TIME		PRI	
	HE	CONV		
	000RFFE, FB Rate			
	000For 000Mins			
	LRP		DF	
ICRPT	IFRPT	INFO		
Zm	DF	1	2	3 4 5
PREV	NEXT		PAN GRID	
CLOS	FRDS	ENMY	HULK	Obs
CLEAR	UP	DN	PRINT	

QUESTIONS?

REGISTERED

TARGETS

ADJ Register a Target

Place a DF at the target location.

Click on **ADJ.** 

Click on **PRI.** 

Toggle to ammunition type. 

Place the Impact Point marker on the DF. 

Select an IF icon. 

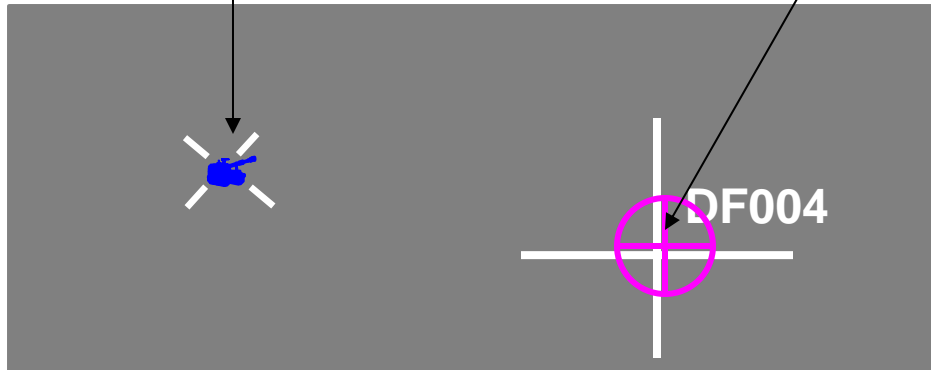

DEPLOY	ADMIN					
GROUP	1	2	3	4	5	
	6	7	8	9	10	
RE-ORG	001	FORCE	001			
COUNTER	00000					
TIMER	00:00:00:00					
GR99A	PP	02000	87001			
RTE	ALT	DEL	CAN	COPY		
ISTOP/GD	HALT		GO			
MOVE	SHOW	SPEED	MAXIMUM			
MOUNT	TRANSFER	ASSIGN				
DISMNT	LINE-F	DEFL	PIT			
VIEW	FORWARD	LOS	FACE			
IC	GP	FM	FC	SD		
ROE	HOLD	SMOKE	GRENADE			
LOSSBS	TRACKER	OPFOR				
INFO	DATA		DETECT			
	MISC	ISR				
DFIR	FORM	SOP	URBAN			
IFIR	AYN	ENG	LOG			
PLN	ALT	EOM	C/F			
ADJ	TIME	PRI				
	HE		CONV			
	000	RFFE, FB	Rate			
	000	For	000	Mins		
		LRP	DF			
ICRPT	IFRPT	INFO				
L						
ZM	DF	1	2	3	4	5
PREV	NEXT	PAN	GRID			
CLOS	FRDS	ENEMY	HULK	Obs		
CLEAR	UP	DN	PRINT			

00:00:00:10

Fire Mission Using a Registered Target

When the Impact Point is within 500 metres of a Registered Target.

Toggle ammunition type, impact pattern **and** RFFE. **Y**

Place an Impact Point marker on the target location. **Y**

Select an IF icon. **Y**

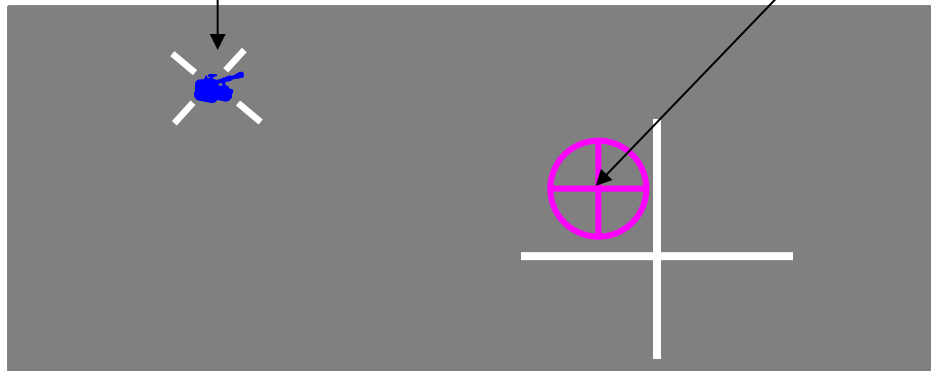

DEPLOY	ADMIN					
GROUP	1	2	3	4	5	
	6	7	8	9	10	
RE-ORG	001	FORCE		001		
COUNTER	00004 .00					
TIMER	00:00:08:00					
GR99A	PP	02000	87001			
RTE	ALT	DEL	CAN	COPY		
I STOP/GO	HALT		GO			
MOVE	SHOW	SPEED		MAXIMUM		
MOUNT	TRANSFER		ASSIGN			
DISMNT	LINE-F	DEFL	PIT			
VIEW	FORWARD	LOS	FACE			
IC	GP	FM	FC	SD		
ROE	HOLD	SMOKE	GRENADE			
LOSSES	TRACKER		OPFOR			
INFO	DATA		DETECT			
	MISC		ISR			
DFIR	FORM	SOP	URBAN			
IFIR	AYN	ENG	LOG			
PLN	ALT	EOM	C/F			
ADJ	TIME		PRI			
	HE		CONV			
	006	RFFE, FB	Rate			
	000	For	000	Mins		
	LRP		DF			
ICRPT	IFRPT	INFO				
Zm	DF	1	2	3	4	5
PREV	NEXT		PAN	GRID		
CLDS	FRDS	ENNY	HULK	DBS		
CLEAR	UP	DN	PRINT			
00:00:00:59						

OTHER MISSION TYPES

PRIORITY MISSION

Click on **IFIR**. **Y**

Click on **PRI**. **Y**

Then follow normal planning sequence.
Preplanned missions will resume once
Priority mission is completed.

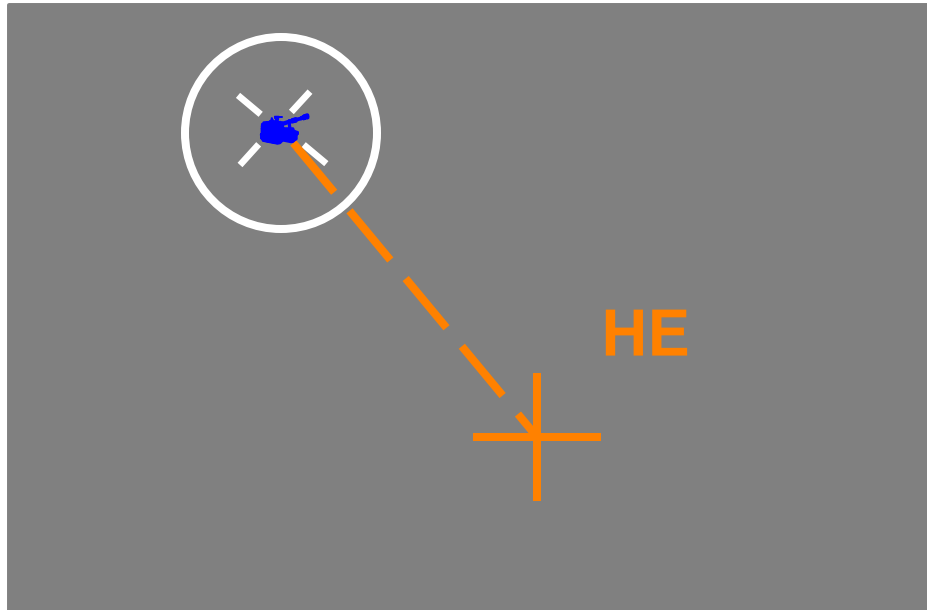

```

DEPLOY                                ADMIN
GROUP 1 2 3 4 5
      6 7 8 9 10
RE-ORG 001 FORCE 001
COUNTER 00000 .00
TIMER 00:00:00:00
GR99A PP 02000 87001
RTE ALT DEL CAN COPY
ISTOP/GO HALT GO
MOVE SHOW SPEED MAXIMUM
MOUNT TRANSFER ASSIGN
DISMNT LINE-F DEFL PIT
VIEW FORWARD LOS FACE
IC GP FM FC SD
ROE HOLD SMOKE GRENADE
LOSSES TRACKER OFFOR
INFO DATA DETECT
      MISC ISR
DFIR FORM SOP URBAN
IFIR AYM ENG LOG
PLN ALT EOM C/F
ADJ TIME PRI
      HE CONV
000RFFE, FB Rate
000For 000Mins
      LRP DF
ICRPT IFRPT INFO
L | | | | | | | | | |
Zm Df 1 2 3 4 5
PREV NEXT PAN GRID
CLOS FRDS ENRY HULK OBS
CLEAR UP DN PRINT

00:00:00:26
  
```

TIME MISSION

Set Timer



Click on **IFIR**



Click on **TIME**.



Then follow normal planning sequence.

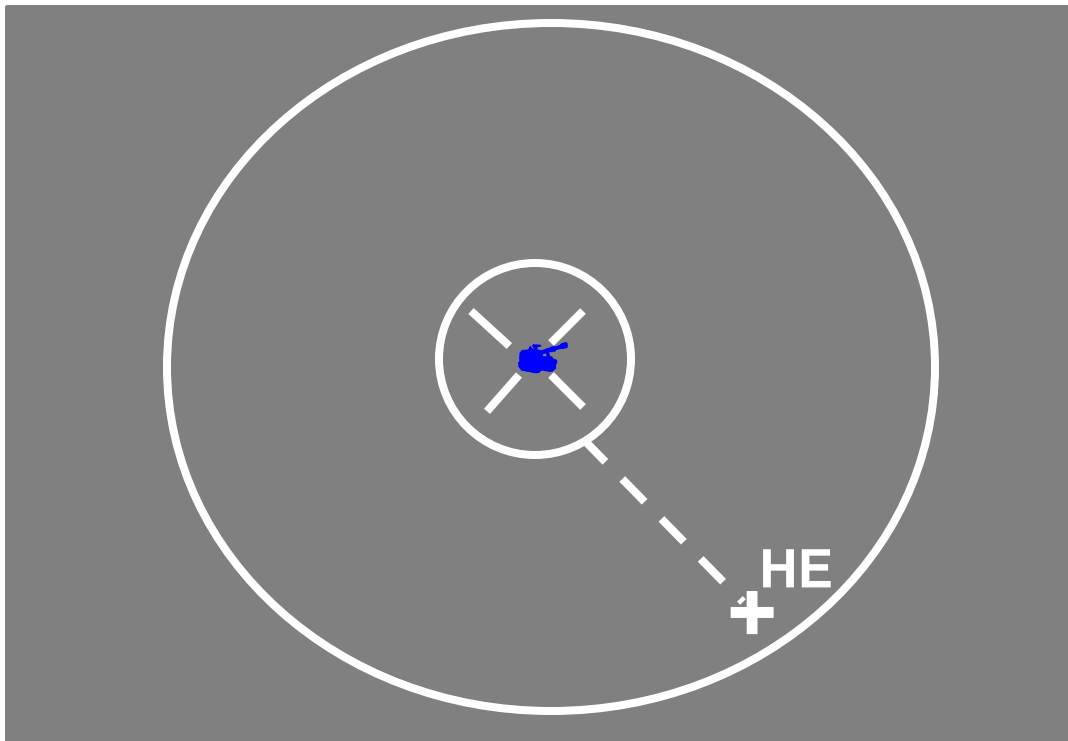



```

DEPLOY ADMIN
GROUP 1 2 3 4 5
      6 7 8 9 10
RE-ORG 001 FORCE 001
COUNTER 00000.00
TIMER 00:00:00:00
GR99A PP 02000 87001
RTE ALT DEL CAN COPY
ISTOP/GO HALT Go
MOVE SHOW SPEED MAXIMUM
MOUNT TRANSFER ASSIGN
DISMNT LINE-F DEFL PIT
VIEW FORWARD LOS FACE
IC GP FM FC SD
ROE HOLD SMOKE GRENADE
LOSSES TRACKER OPFOR
INFO DATA DETECT
      Misc ISR
DFIR FORM SOP URBAN
IFIR AYN ENG LOG
PLN ALT EDM C/F
ADJ TIME PRI
      HE CONV
000RFFE, FB Rate
000For 000Mins
      LRP DF
ICRPT IFRPT INFO
L | | | | | | | | | |
ZM DF 1 2 3 4 5
PREV NEXT PAN GRID
CLOS FRDS ENMY HULK OBS
CLEAR UP DN PRINT
00:00:00:28
  
```

LINEAR MISSION

Click on **IFIR** 

Toggle to **LINEAR**, set mission details 

Click options on **PLN** to set one end of the linear target.   

Click on terrain to set the other end of the linear target. 

Select IF icon(s). 

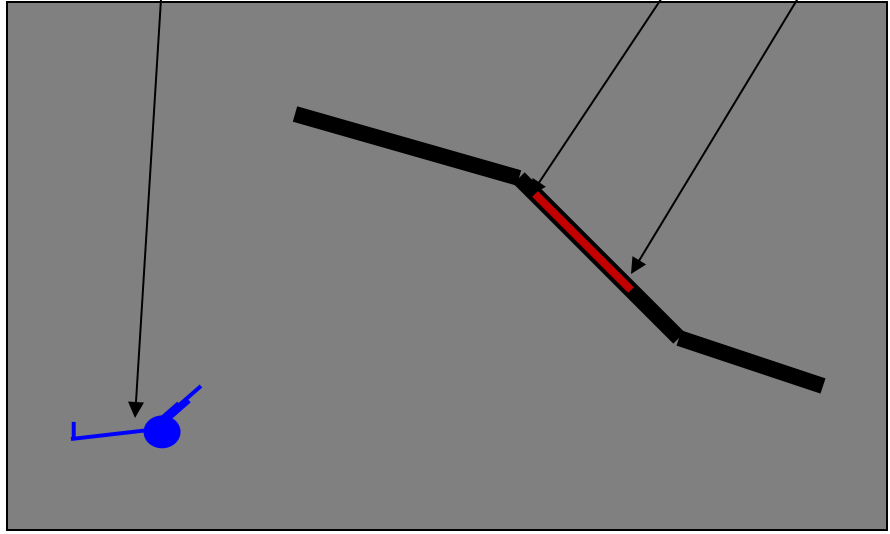

DEPLOY	ADMIN				
GROUP	1	2	3	4	5
	6	7	8	9	10
RE-ORG	001	FORCE		001	
COUNTER	00000 .00				
TIMER	00:00:00:00				
GR99A	PP	02000	87001		
RTE	ALT	DEL	CAN	COPY	
ISTOP/GO	HALT		GO		
MOVE	SHOW	SPEED		MAXIMUM	
MOUNT	TRANSFER		ASSIGN		
DISMNT	LINE-F	DEFL	PIT		
VIEW	FORWARD	LOS	FACE		
IC	GP	FM	FC	SD	
ROE	HOLD	SMOKE		GRENADE	
LOGSES	TRACKER		OPFOR		
INFO	DATA		DETECT		
	MISC		ISR		
DFIR	FORM	SOP	URBAN		
IFIR	AYM	ENG	LOG		
PLN	ALT	EOM	C/F		
ADJ	TIME	PRI		HE	
				LINEAR	
	000	RFFE	FB		Rate
	000	For	000 Mins		
	LRP		DF		
ICRPT	IFRPT	INFO			
ZM	DF	1	2	3	4
PREV	NEXT		PAN	GRID	
CLDS	FRDS	ENMY	HULK	DBS	
CLEAR	UP	DN	PRINT		
00:00:01:09					

FASCAM MISSION

```

DEPLOY              ADMIN
GROUP              1 2 3 4 5
                  6 7 8 9 10
RE-ORG             001 FORCE 001
COUNTER           00000 .00
TIMER             00:00:00:00
GR99A PP 02000 87001
RTE ALT DEL CAN COPY
ISTOP/GD HALT Go
MOVE SHOW SPEED MAXIMUM
MOUNT TRANSFER ASSIGN
DISMNT LINE-F DEFL PIT
VIEW FORWARD LOS FACE
IC GP FM FC SD
ROE HOLD SMOKE GRENADE
LOSSES TRACKER OPFOR
INFO DATA DETECT
MISC ISR
DFIR FORM SOP URBAN
IFIR AYN ENG LOG
PLN ALT EDM C/F
ADJ TIME PRI
FASCAM FAS 2
000RFFE, FB Rate
000For 000Mins
LRP DF
ICRPT IFRPT INFO
L | | | | | | | | | |
Zm Df 1 2 3 4 5
PREV NEXT PAN GRID
CLDS FRDS ENMY HULK OBS
CLEAR UP DN PRINT
00:00:01:48
  
```

Select **PRIORITY** **Y**

Select **FASCAM** **Y**

Toggle **FASCAM Type** **Y**

B

PLN options for **Centre Point** of Mine Panel

Set **Orientation** of the Mine Panel

W select IF icon(s)

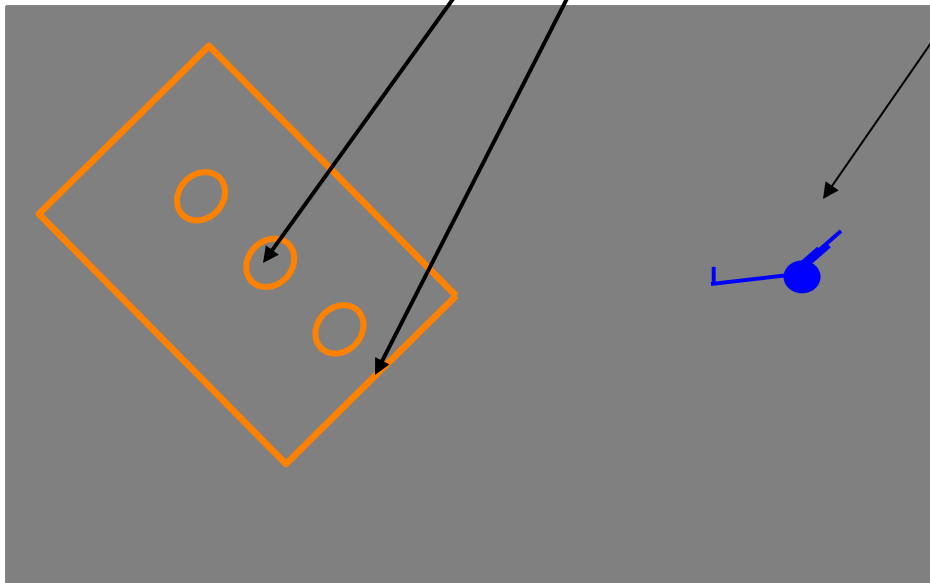

QUESTIONS?

LASER DESIGNATION

Laser Engagement Profile

Designator must be within 45° of line firer-target.

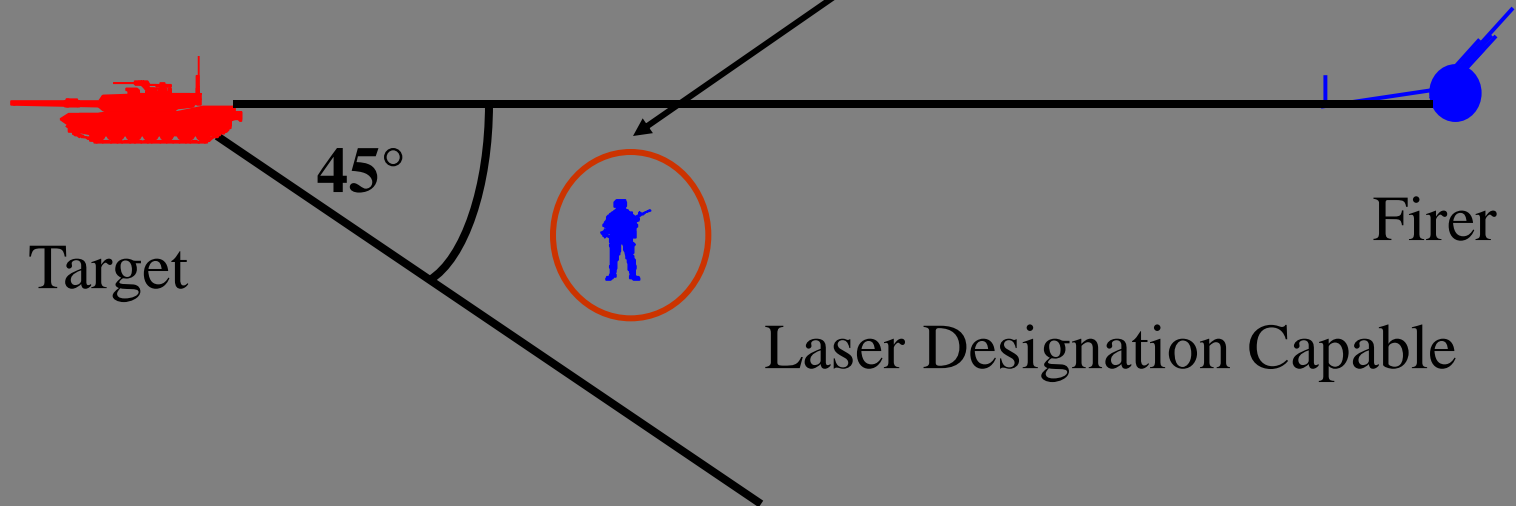

Target

45°

Firer

Laser Designation Capable

LASER DESIGNATION

Click on **DESIG**
 (orange circle appears around all laser
 designator capable icons available) [1]

Select a Designator icon
 (white line appears to observed targets) [2]

Select a target icon
 (orange line appears to selected target and
 an orange circle surrounds the target) [3]

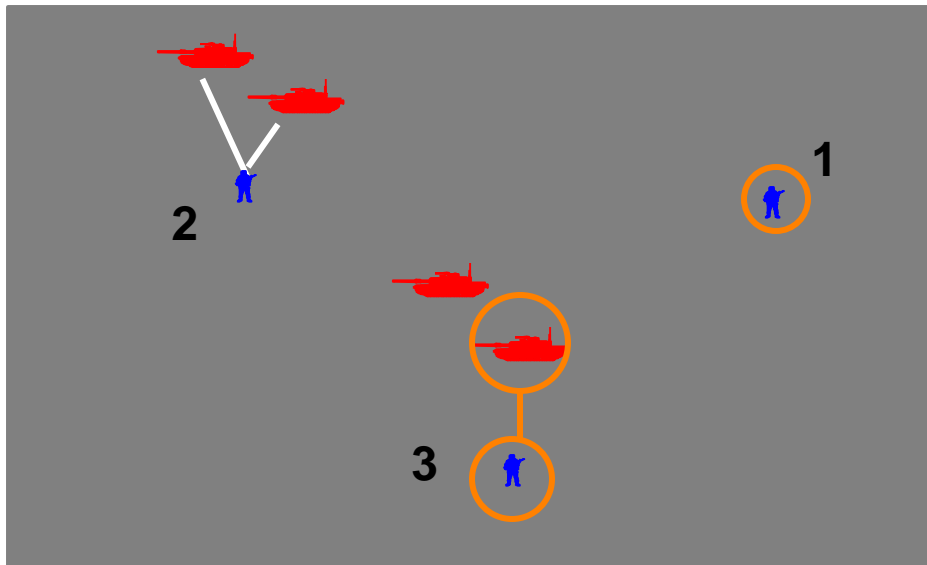

DEPLOY	ADMIN				
GROUP	1	2	3	4	5
	6	7	8	9	10
RE-ORG	001	FORCE	001		
COUNTER	00000				
TIMER	00:00:00:00				
GR99A	PP	02000	87001		
RTE	ALT	DEL	CAN	COPY	
ISTOP/GO	HALT		GO		
MOVE	SHOW	SPEED	MAXIMUM		
MOUNT	TRANSFER	ASSIGN			
DISMNT	LINE-F	DEFL	PIT		
VIEW	FORWARD	LOS	FACE		
IC	GP	FM	FC	SD	
ROE	HOLD	SMOKE	GRENADE		
LOSSBS	TRACKER	OPFOR			
INFO	DATA		DETECT		
	MISC	ISR			
DFIR	FORM	SOP	URBAN		
IFIR	AYN	ENG	LOG		
WLR	ON/OFF	ANGLE			
	SETUP	REPORT			
MMR	FOOT	SAR	GMTI		
SENSOR					
DESIG					
CUE TGT					
					INFO
L					
Zm	DF	1	2	3	4
PREV	NEXT	PAN	GRID		
CLDS	FRDS	ENEMY	HULK	DBS	
CLEAR	UP	DN	PRINT		
					00:00:00:14

Cancel Laser Designation

Click on **DESIG**
 (orange circle appears around all laser
 designator capable icons available)

Click on icon displaying a current designating
 mission

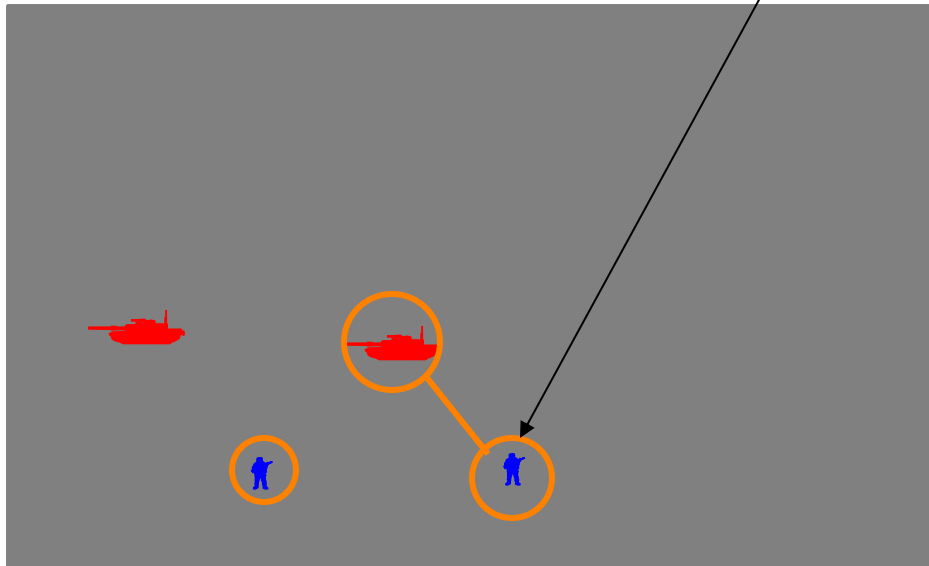

Y

G

DEPLOY	ADMIN				
GROUP	1	2	3	4	5
	6	7	8	9	10
RE-ORG	001	FORCE	001		
COUNTER	00000				
TIMER	00:00:00:00				
GR99A	PP	02000	87001		
RTE	ALT	DEL	CAN	COPY	
ISTOP/GO	HALT		Go		
MOVE	SHOW	SPEED	MAXIMUM		
MOUNT	TRANSFER	ASSIGN			
DISMNT	LINE-F	DEFL	PIT		
VIEW	FORWARD	LOS	FACE		
IC	GP	FM	FC	SD	
ROE	HOLD	S MOKE	GRENAD		
LOGSES	TRACKER	OPFOR			
INFO	DATA		DETECT		
	MISC	ISR			
DFIR	FORM	SOP	URBAN		
IFIR	AYN	ENG	LOG		
	ON/OFF	ANGLE			
WLR	SETUP	REPORT			
MMR	FOOT	SAR	GMTI		
SENSOR					
DESIG					
CUE TGT					
				INFO	
ZM	DF	1	2	3	4
PREV	NEXT	PAN	GRID		
CLOS	FRDS	ENMY	HULK	Obs	
CLEAR	UP	DN	PRINT		
					00:00:00:14

**PRECISION
GUIDED
MUNITIONS**

Laser Engagement Profile

Self Designating Aircraft

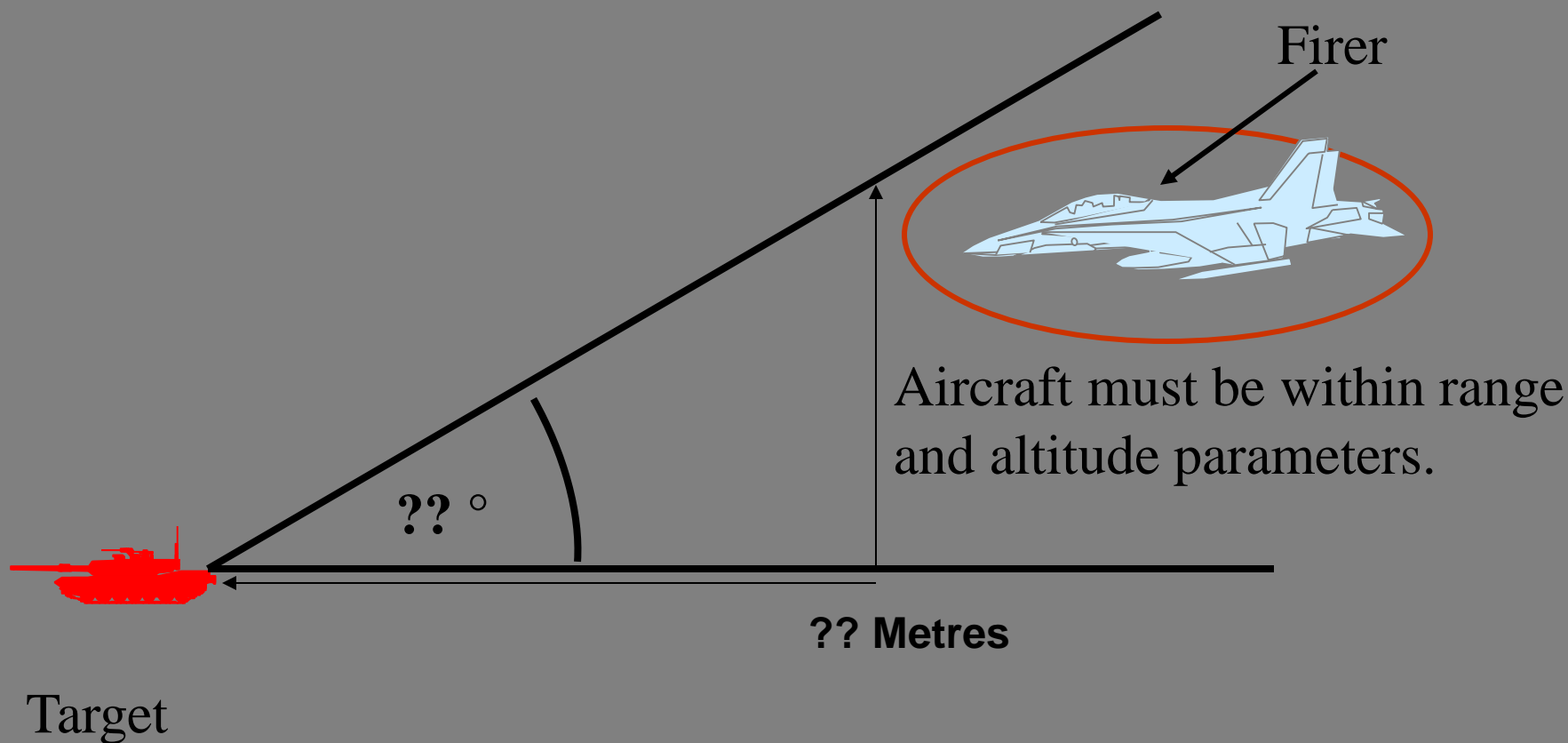

QUESTIONS?

QUESTIONS?

**FINAL
QUESTIONS?**